

S.NO	CATALOG NUMBER	A	T	B	LINE 1	LINE 2	LINE 3	LINE 4
1	AL250	1.06 [27]	0.31 [8]	0.59 [15]	CMC/ESP AL250	4/0-250 STR	250 COMPT	12A 13A 299 655 705
2	AL300			0.66 [17]	CMC/ESP AL300	250-300 STR	300 COMPT	12A 13A 299 655 705
3	AL350			0.72 [18]	CMC/ESP AL350	300-350 STR	350 COMPT	12A 13A 299 655 705
4	AL350S	0.91 [23]	0.25 [6]	0.72 [18]	CMC/ESP AL350S	300-350 STR	350 COMPT	840 845 249 11A
5	AL4/0			0.55 [14]	CMC/ESP AL4/0	4/0 STR	4/0-250 COMPT	.840 845 249 TX 11A
6	AL3/0			0.49 [12]	CMC/ESP AL3/0	3/0 STR	3/0 COMPT	.840 845 249 TX 11A
7	AL2/0			0.45 [11]	CMC/ESP AL2/0	2/0 STR	2/0 COMPT	.840 845 249 TX 11A
8	AL1/0A			0.40 [10]	CMC/ESP AL1/0A	1/0 STR	1/0 & 2/0 COMPT 2/0 SOL	.840 845 249 TX 11A
9	AL1/0			0.40 [10]	CMC/ESP AL1/0	1/0 STR	1/0 & 2/0 COMPT	8A 5/8 BG 243
10	AL10			0.15 [4]	CMC/ESP AL10	10 STR	8 SOL	8A 5/8 BG 243
11	AL2			0.64 [16]	0.19 [5]	0.34 [9]	CMC/ESP AL2	2 & 1 STR
12	AL4	0.27 [7]	CMC/ESP AL4			4 STR	4 COMPT 2 SOL	8A 5/8 BG 243
13	AL6	0.22 [6]	CMC/ESP AL6			6 STR	6 COMPT 4 SOL	8A 5/8 BG 243
14	AL8	0.17 [4]	CMC/ESP AL8			8 STR	8 COMPT 6 SOL	8A 5/8 BG 243

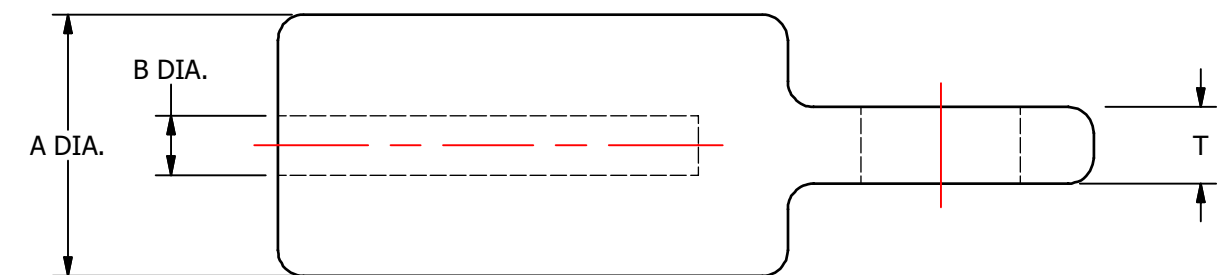
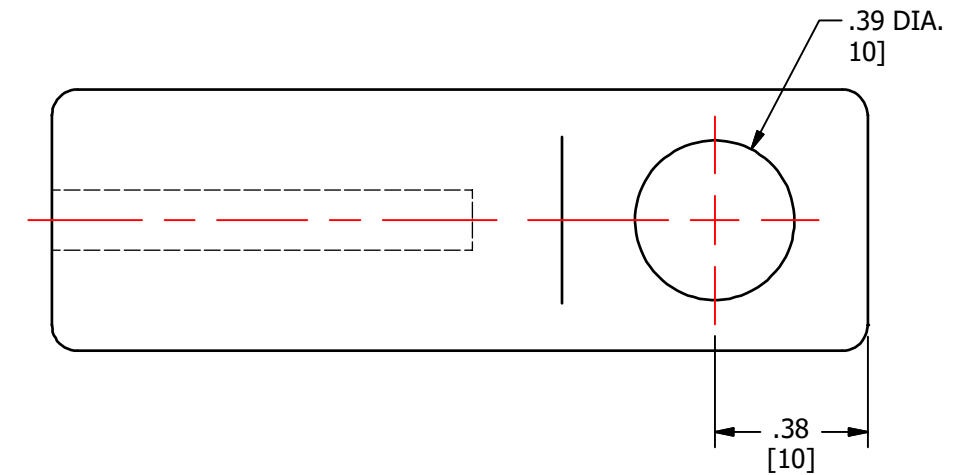
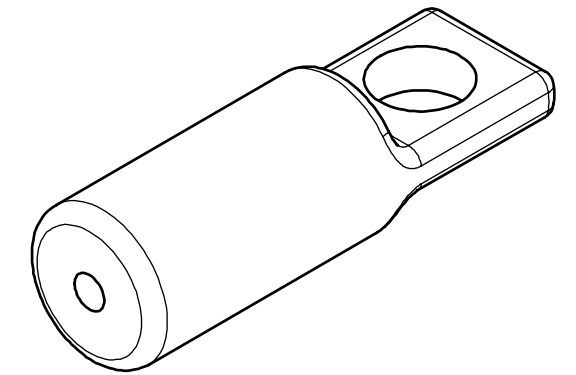

MATERIAL: ALUMINUM

				DRAWN BY: TS 07-11-19		NAME OF PART: LUG ASSEMBLY		CAT. NO.: SEE TABLE	
				CHECKED BY:		DWG NO: U55495033-S (CHARTED)		B	
A NEW DRAWING CREATED				07-11-19		TS		FOR PRODUCT INFO: <a href="http://www.cmclugs.com">http://www.cmclugs.com</a>	
REV.	DESCRIPTION	ECN	DATE	INIT.	DRAWING NOT TO SCALE			SHEET NO: 1 OF 1	

THIS INFORMATION IS PROPRIETARY TO CONNECTOR MFG. CO. AND IS NOT TO BE DISCLOSED OUTSIDE OF CONNECTOR MFG. CO. WITHOUT A CONFIDENTIALITY AGREEMENT



CONNECTOR MANUFACTURING CO.

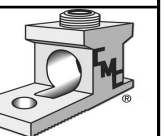

HAMILTON, OHIO